

**Saldet** Sales & Service, Inc.

44810 VIC WERTZ DRIVE, SUITE B

CLINTON TOWNSHIP, MICHIGAN 48036-1250

PHONE: (586) 469-4312 FAX: (586) 463-2518

1 ( 888) 621-6221

**Form 1250B**

# ***SHORT-STOP***

## **Electronic Motor Brake**

### **Type - G**

## **Instructions**

**SALDET SALES & SERVICE, INC.  
CLINTON TOWNSHIP, MICHIGAN**

# Table of Contents

1. INTRODUCTION.....	2
2. DESCRIPTION AND APPLICATIONS.....	2
3. SAFETY NOTES.....	2
4. LIMITATIONS.....	2
5. RATINGS.....	2
6. INSTALLATION.....	3
6.1 Mounting.....	3
6.2 Wiring.....	3
6.3 Interlock Terminals 3 and 4.....	3
6.4 Power Wiring.....	4
6.4.1 Single Direction, Single Speed.....	4
6.4.2 Forward and Reverse.....	4
6.4.3 Wound Rotor Motors.....	4
6.4.4 Electronic Drives.....	5
6.4.5 Single Phase.....	5
7. OPTIONS.....	5
7.1 Programmable Controller Mode.....	5
7.2 Option L (45 sec. max. braking time.).....	5
7.3 Option S (Higher Torque).....	5
7.4 Option BD / Y (Brake Disable/Timeout).....	5
7.5 Option D (Dual-voltage operation).....	5
7.6 Option R (Braking using 3 motor windings).....	5
7.7 Option P (Braking on demand).....	5
8. ADJUSTMENTS.....	6
8.1 Description of the Adjustments.....	6
8.2 Setting the Adjustments.....	6
9. HOW THE SHORT-STOP WORKS.....	6
9.1 Basic Concept.....	6
9.2 Operation.....	7
10. IF YOU HAVE A PROBLEM.....	7
10.1 Preliminary Checks.....	7
10.2 No Braking When Motor is Turned OFF.....	7
10.3 Motor Will Not Start.....	8
10.4 Before Returning Any Unit For Service:.....	8
11. LIMITED WARRANTY.....	8

## 1. INTRODUCTION

The SHORT-STOP electronic motor brake permits rapid stopping of AC motors by DC injection, creating a stationary magnetic field within the motor.

Braking action is smooth, adjustable and frictionless.

Torque and time adjustments permit matching the braking rate to almost any machine requirement.

The installation of standard units simply involves connection of six wires to the machine motor starter.

The SHORT-STOP has no effect on normal machine performance, operation or motor life.

### - FEATURES -

- FRICTIONLESS BRAKING
- TORQUE IS FULLY ADJUSTABLE
- NO MECHANICAL CONNECTIONS
- INTERNAL FUSES FOR PROTECTION

## 2. DESCRIPTION AND APPLICATIONS

The SHORT-STOP works with all AC motors other than universal types. Each SHORT-STOP model covers all motor sizes up to its rating for horsepower and amps.

Standard units are completely satisfactory for most applications, particularly woodworking and metalworking machines such as saws, lathes, grinders, sanders, etc.

Other applications are to replace worn-out mechanical brakes, to minimize maintenance and to provide adjustable stopping rates. They make retrofitting older machines easy, since no mechanical connection is required.

Electronic brakes are useful where coasting is either a production or a safety problem. However, since electronic brakes require power to operate and do not provide holding, they cannot be used as "fail-safe" brakes.

## 3. SAFETY NOTES

LOCK TOOL OR BLADE SECURELY. Saws and grinders are often fastened with left-hand thread devices, which tend to loosen when the machine is stopped too quickly. Use of double nuts, or other positive locking methods to prevent such loosening. Since braking may be set to exceed starting torque, test for safe operation during braking and check locking from time to time.

DON'T TAMPER WITH WIRING OR MAGNETIC CONTACTOR. Once installed and adjusted, the SHORT-STOP box cover should be closed securely. Tampering with the internal parts or manually operating the magnetic contactor is not only dangerous, but can cause damage not covered by the warranty.

POWER LINE INTERRUPTION. The SHORT-STOP uses AC line power to achieve its braking action. Thus a power failure or disconnect, or the opening of a fuse, will simply let the motor coast to a stop without braking. Do not use the SHORT-STOP where failure to provide braking will be a hazard.

HOLDING AGAINST A LOAD. The SHORT-STOP cannot be used as a positive brake against overhauling loads after the motor stops. In such applications, a positive lock, a pin, or a separate mechanical brake must be used to provide for holding at rest. Call factory for information on other models if holding is desired.

## 4. LIMITATIONS

MOTOR TYPES. The SHORT-STOP will work with all induction motors, including wound rotor types, and with all three phase motors. It will work with all single-phase motors except for DC and universal motors.

MOTOR HEATING. The heat generated during braking can be considered equivalent to adding another start cycle, if the TORQUE control is set very high. Therefore, high cycle operations may require fan cooling.

Although motor heating is rarely a problem, it is minimized by using the lowest torque setting that gives acceptable operation.

**IT IS UP TO THE USER TO INSURE THAT HIS MOTOR WILL BE PROTECTED FROM EXCESSIVE HEAT RISE, WHETHER FROM EXTREMES OF RUNNING, STARTING OR BRAKING.**

POWER OR FUSE FAILURE. Loss of power means loss of braking, regardless of whether power is disconnected by a switch, line or internal fuse, circuit breaker, etc. This also applies to fuses internal to the SHORT-STOP, where the fuses are intended for the protection of internal components.

POWER FACTOR CAPACITORS. Power factor capacitors may NOT be used across a LOAD controlled by the SHORT-STOP. Move any such capacitors to the LINE side of the starting contactor per NEC Procedures.

DON'T OPEN POWER TO TERMINALS 1 AND 2. If power is simply removed from the power input terminals of the SHORT-STOP during braking, the power contactor will open under load and may damage the SHORT-STOP, and will not stop the motor.

## 5. RATINGS

All SHORT-STOP units may usually be used up to the published ratings of horsepower or current - whichever is

less.

Any application requiring frequent or severe braking, or operation more often than two stops per minute may require a different model SHORT-STOP.

Applications involving exceptionally high inertia, such as press flywheels, extractors, etc may require models with longer than the standard 15-second maximum braking time.

For information on applications such as these, please consult the factory or your local sales representative.

All SHORT-STOP units may be used in normal ambient temperatures. The maximum temperature at the hottest part of the heat sink should not exceed 50 degrees C.

SHORT-STOP units have internal fuses. These are fast-acting, semiconductor fuses. They must be replaced with the same type as originally supplied. **THE USE OF IMPROPER FUSES IN THE SHORT-STOP WILL VOID THE WARRANTY!!!**

## 6. INSTALLATION

### 6.1 Mounting

The SHORT-STOP may be mounted in any convenient location, and in any orientation, although vertical is preferable. Keep it away from sources of vibration, dust, dirt and extremes of temperature. Once mounted, it normally needs no maintenance.

### 6.2 Wiring

ALL WIRING SHOULD CONFORM WITH NATIONAL AND LOCAL ELECTRICAL CODES.

	<b>DISCONNECT AND LOCK OUT POWER TO SHORT-STOP TERMINALS 1 AND 2 BEFORE SERVICING THE SHORT-STOP</b>
--	--

All wiring to the SHORT-STOP is connected to the terminals provided. In general, the wires connected to Terminals 1, 2, 5 and 6 must be able to carry the full motor starting and running current.

Wires connected to Terminals 3, 4, S, W, B and Y will carry control currents only and may be of the same gauge as the control wires for the motor starting contactor.

### 6.3 Interlock Terminals 3 and 4

	<b>THIS IS THE MOST IMPORTANT PART OF THE INSTALLATION. IF THIS WIRING IS NOT DONE CORRECTLY, THE WARRANTY IS VOID.</b>
--	---

Terminals 3 and 4 must be connected IN SERIES with the motor starting contactor coil(s). This can be done by putting Terminals 3 and 4 IN SERIES with the motor overload protection contacts, or IN SERIES with the control system STOP button.

Figures 6.1 - 6.3 show some typical control systems, with interlock Terminals 3 and 4 wired appropriately.

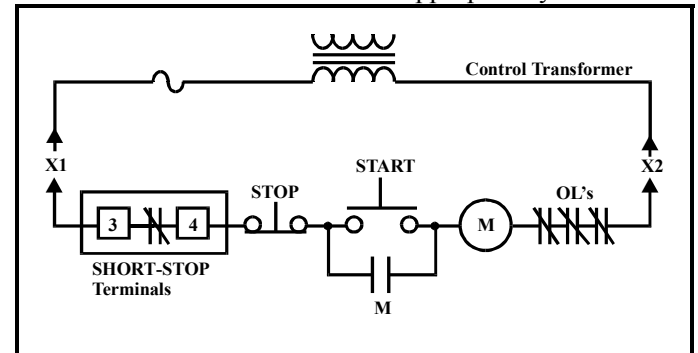

Figure 6.1 Single Direction with Control Transformer

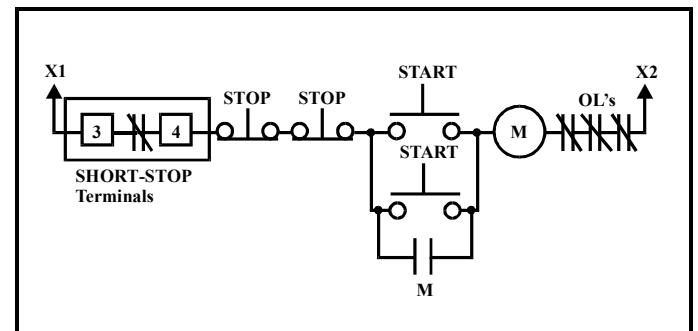

Figure 6.2 Multiple Station Control

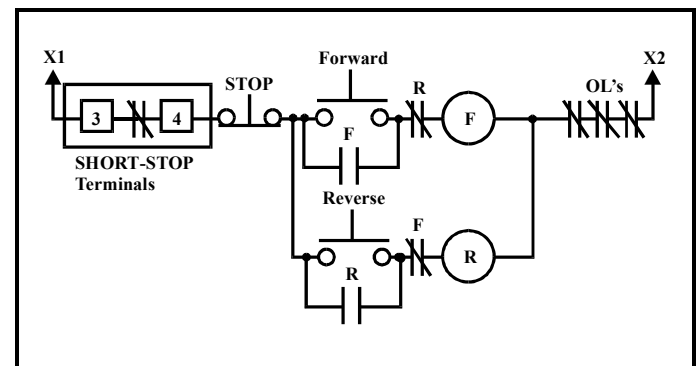

Figure 6.3 Forward / Reverse System

During normal running operation the interlock is closed and conduction takes place between Terminals 3 and 4.

During braking, this interlock circuit opens up, to lock out the motor starting contactor or contactors. If the interlock is not connected properly, it may be possible to energize both the run and the brake contactors at the same time, and damage the SHORT-STOP.

**WARNING**

Control voltage must not exceed 240 VAC.

Never connect Terminals 3 and 4 across (in *parallel* with) the motor starter contactor coil or across the power line!

The motor starter contactor and brake contactor must not be manually operated when the SHORT-STOP is connected, as this will blow fuses and damage the unit.

Terminals 3 and 4 are connected to an electronic switch, and cannot be tested for continuity with an ohmmeter

**MANDATORY INTERLOCK TEST**

- With Power Off, remove all wires from terminals 1 & 2
- After Terminals 3 and 4 have been connected. Turn main power ON.
- Try to start motor, using ALL start buttons or controls.
- MOTOR SHOULD NOT START. If it does start, your wiring is NOT CORRECT. Turn power OFF, revise wiring, and re-test.

**6.4 Power Wiring**

Only AFTER the interlock has been correctly connected and the mandatory test has been passed successfully, the power wiring may be done.

As shown in the circuit diagrams below and on the typical wiring diagram inside the SHORT-STOP enclosure, power conductors (capable of carrying the full motor starting and running currents) should be connected to Terminals 1, 2, 5 and 6.

For typical power wiring arrangements, see Figures 6.4 to 6.6.

**6.4.1 Single Direction, Single Speed**

For single direction single speed applications follow the "Typical Short Stop Installation Wiring" supplied inside the Short Stop enclosure, or Figure 6.4.1.  
Figure 6.4.1 Single Direction, Single Speed

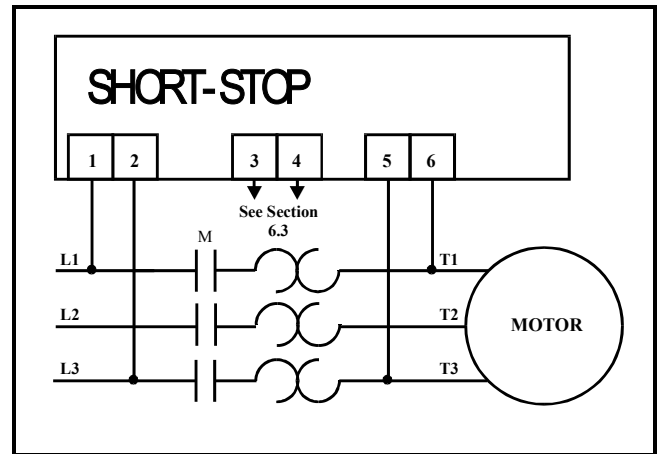

**6.4.2 Forward and Reverse**

As can be seen from Figure 6.4.2, the power wiring for a bi-directional system is essentially the same as for the basic single direction installation.

Please refer back to Section 6.3, however, to insure that the interlock is connected so as to disable BOTH the forward and the reverse motor starters during braking.

Braking will take place when stopping from EITHER direction.

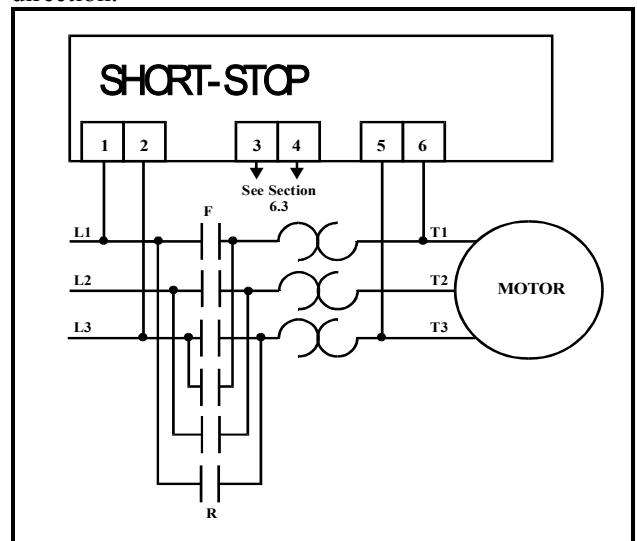

Figure 6.4.2 Forward / Reverse System

**6.4.3 Wound Rotor Motors**

Wound rotor motors require no special attention, since they are also induction motors. Any motor wired with the SHORT-STOP must, of course, be used with a Magnetic Starter so that the interlock can be wired correctly. Minimum resistance should be connected to the rotor circuit during braking.

## 6.4.4 Electronic Drives

When used with electronic drives such as motor accelerators, solid state starters, variable frequency drives, etc., an isolating contactor must be installed between the motor and the electronic drive device to protect the electronic drive.

The coil of the contactor must be interlocked with Terminals 3 and 4 of the SHORT-STOP; see Figs. 6.1 to 6.3.

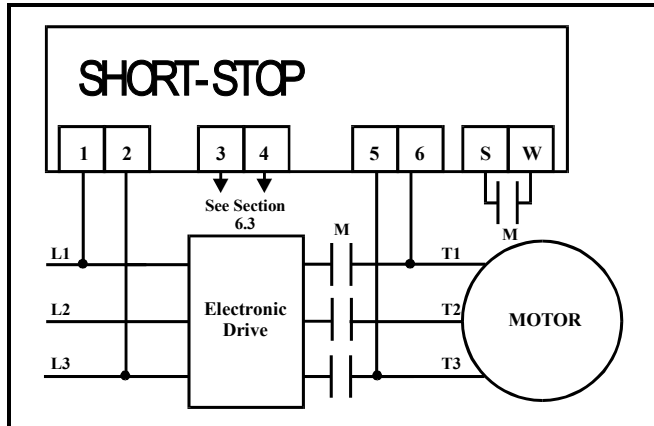

Figure 6.4.4 With Electronic Drives

## 6.4.5 Single Phase

Refer to Fig. 6.4.1 (Single Direction, Single Speed.) Use L1 & L2, rather than L1 & L3 for the power source.

Note that for a given voltage and horsepower rating, a single-phase machine will draw greater current than the three-phase equivalent. Be sure not to exceed either the horsepower or current rating of the SHORT-STOP.

## 7. OPTIONS

### 7.1 Programmable Controller Mode

If your motor starter is controlled by a programmable controller or other type of solid state switch, or if the electronic brake does not activate after the motor has been run, then:

- Connect Terminals S and W to a dry normally open (N/O) auxiliary contact on all starter contactors.
- Set the "ILK SENSE" switch (located to the right of the brake LED on the control board) to the OFF position.

### 7.2 Option L (45 sec. max. braking time.)

Maximum braking time is 45 seconds. No additional wiring or controls involved. (Other braking times are also available)

### 7.3 Option S (Higher Torque)

The maximum braking torque is higher than for standard models. No additional wiring or controls are involved.

### 7.4 Option BD / Y (Brake Disable/Timeout)

Permits the brake to be disabled for certain purposes, such as jogging or setup. To use this option, connect a DRY contact or switch to Terminals B and Y. If the switch or contact is closed during the run to brake transition, no brake cycle will follow (motor coasts to a stop). If the switch or contact is closed during a brake cycle, the brake cycle will be terminated.

### 7.5 Option D (Dual-voltage operation)

On "dual-voltage" rated units, permits a single SHORT-STOP to be used on either 230 OR 460 volts.

### 7.6 Option R (Braking using 3 motor windings)

May be used to excite all three windings. With this option, the third motor lead is connected to Terminal 7. All other connections are made as described for standard units.

## 7.7 Option P (Braking on Demand)

For applications where a braking cycle is not always needed when stopping the motor, refer to the wiring diagram in Figure 7.7. This configuration will initiate a braking cycle **only** if the braking on demand push-button is engaged. Otherwise, the motor will coast to rest when the regular stop push-button is engaged.

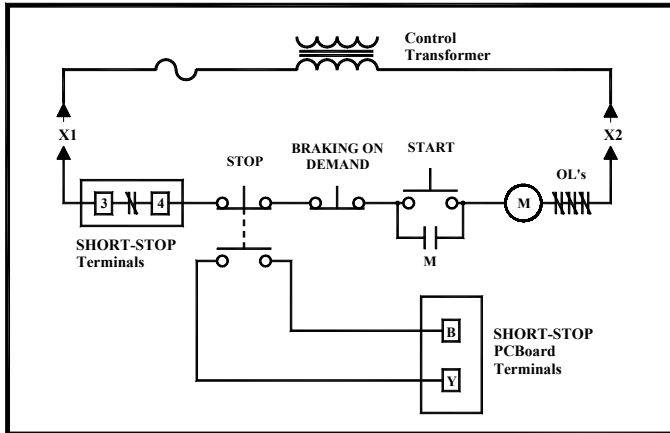

Figure 7.7 Braking on Demand

## 8. ADJUSTMENTS

### 8.1 Description of the Adjustments

Two adjustment controls are provided within the SHORT-STOP. These determine the amount of braking power applied to the motor (TORQUE) and the length of time this power is applied (TIME).

#### CAUTION

With high torque settings, this brake can loosen self-tighten shaft mounted cutting tools. Be certain that tool arbor is keyed, double nutted, or locked very tightly. Test locking mechanism for secure operation periodically.

These controls are single turn potentiometers, which can be set by means of a small screwdriver (An insulated screwdriver is recommended). Both controls are at their minimum when turned fully counter clockwise.

**DO NOT FORCE THE ADJUSTMENT PAST THE END STOPS!**

Once set for a particular application, the controls should not have to be re-adjusted.

A red LED indicator on the circuit board is illuminated during braking.

### 8.2 Setting the Adjustments

- (1) Set TIME control (located on the logic board, to the left of the brake LED) to mid-range
- (2) Set TORQUE control (located on the phase-shift board, below the fuses) to minimum (Full counter clockwise)
- (3) Turn main power ON
- (4) Turn motor ON. After full speed is reached, turn motor OFF
- (5) Adjust TORQUE control in 1/8 turn steps to reach desired safe braking rate. Braking action is indicated by a slight hum of the motor.
- (6) Adjust TIME control so that braking hum stops (and LED goes out) about one second after motor stops.
- (7) Repeat steps 4 to 6 above, until a satisfactory stopping time is reached. The maximum tolerable stopping time should be used.

#### CAUTION

AS THE MOTOR HEATS UP, THE WINDING RESISTANCE WILL INCREASE. THIS MAY REQUIRE A LONGER APPLICATION OF THE BRAKING CURRENT. THEREFORE, SET THE TIME CONTROL EITHER WITH THE MOTOR HOT, OR SO AS TO "HANG ON" FOR ABOUT A SECOND AFTER STOPPING A COLD MOTOR.

Applying the brake for a longer time than necessary serves only to increase motor heating.

## 9. HOW THE SHORT-STOP WORKS

### 9.1 Basic Concept

The principle used by the SHORT-STOP is the injection of a controlled amount of DC (Direct Current) into an AC motor to achieve braking. The effect in stopping can be considered completely equivalent to that at motor startup. The DC current in the motor stator sets up a stationary magnetic field in which the rotor is turning. The

interaction between the rotor and the magnetic field tries to align the rotor with the field. Thus, the SHORT-STOP actually drives the rotor to zero speed.

A further feature is that the retarding torque is proportional to the field strength, and hence to the braking current. By varying the braking current, the braking strength can be set to any desired value.

## 9.2 Operation

When any START button is depressed, the motor will start instantly, provided a brake cycle is not in progress. Starting the motor primes the brake.

When the STOP button is depressed and the starter contactor is released, the SHORT-STOP will begin braking the motor, after a short delay.

The length of the brake cycle is determined by the Time control, and the amount of braking is determined by the Torque control.

If Terminals B and Y are closed during a run to brake transition, the brake will not activate and the motor will coast to a stop.

## 10. IF YOU HAVE A PROBLEM

### 10.1 Preliminary Checks

No adjustments are provided or required other than those described in Section 8.

Should a system fail to perform properly, be sure to check the wiring first. Also, be certain that the power line voltage is present and correct. For instance, there should be equal voltages between any two leads of a three-phase power line, and these should be in the correct nominal range for the SHORT-STOP.

If the system has previously been operating properly, it is also a good idea to check fuses, and that the adjustments of the two controls - TIME and TORQUE - have not been tampered with.

If there is a problem on initial installation, or if the brake should fail to function properly, the following checks should be made:

[A] Check that TIME and TORQUE controls are set properly, and are not at minimum.

[B] Verify that the SHORT-STOP rated motor voltage is present at Terminals 5 and 6 WHEN THE MOTOR RUNS. If there is NO voltage at 5 and 6 with the motor running, the unit is installed incorrectly.

[C] Verify that there is normal line voltage (SHORT-STOP rated voltage) across Terminals 1 and 2, and

that there is AC voltage at the output of the control transformer in the SHORT-STOP if one is present. (Lack of voltage at these places may indicate a blown line fuse, etc.)

[D] If you do not have a programmable controller operating your motor starter contactor, verify that the "ILK SENSE" switch (located to the right of the brake LED on the control board) is in the ON position.

[E] If you have a programmable controller operating your motor starter contactor, refer to section 7.1

Note that 230-volt units operated from 208 volts will produce somewhat lower torque. Consult the factory if this is a problem.

If the power line fuses blow at high torque settings, the brake should be removed from the motor power line, and operated from a separate disconnect fused at the same rating as the motor.

### 10.2 No Braking When Motor is Turned OFF.

[ ] First, verify that the unit is installed and wired correctly.

[ ] Next, check that the TIME and TORQUE adjustments are not set too low.

[ ] Check for blown fuses in the supply line and in the SHORT-STOP.

Possible reasons for blown fuses are:

[ ] Interlock not operating properly - the most likely cause is that it is wired wrong, OR NOT AT ALL!

[ ] Overloading of the SHORT-STOP. Replace fuses, and try operating at lower braking torque. If fuses do not blow until torque is turned up, the SHORT-STOP chosen was probably too small for the application.

[ ] Power factor capacitors, if used, MUST NOT be across the load

**CAUTION**

Fuses in the SHORT-STOP are designed to protect the internal components. They are of a special fast-acting semiconductor-protecting type, and **MUST** be replaced with the same type of equal or lower current rating.

**THE USE OF INCORRECT REPLACEMENT FUSES WILL VOID THE WARRANTY, AND MAY RESULT IN FURTHER DAMAGE TO THE EQUIPMENT.**

If there is still a problem, internal trouble is indicated and the unit should be returned to the factory for service. **BEFORE RETURNING ANY UNIT TO THE FACTORY**, be sure to make the observations and to follow the requirements of Section 10 4

**10.3 Motor Will Not Start**

When SHORT-STOP is Connected.

[ ] This is usually due to an open interlock (Terminals 3 & 4). **NOTE:** The INTERLOCK requires power be applied to the Terminals 1 and 2 to operate, and cannot be checked for continuity with an ohmmeter. See Section 10.1-C.

**10.4 Before Returning Any Unit For Service:**

- (1) Measure and document the voltage across Terminals 1, 2, 5 and 6.
- (2) Document the motor operating voltage, current and horsepower.
- (3) **REQUEST PERMISSION FOR THE RETURN**, specifying all the above, plus the type of application or use, and the number of phases involved. Be sure to supply the unit Serial Number, Model Number, and to list all options provided.
- (4) **PACK THE UNIT CAREFULLY**, so that there will be no further damage during shipment.
- (5) Be sure to include your name, address, telephone number, and the address to which the repaired unit is to be sent.
- (6) When returning any unit include a brief description of the difficulty you are having, as well as any tests you have made on it.
- (7) Collect shipments will not be accepted.

**11. LIMITED WARRANTY**

Each SHORT-STOP is warranted by the factory for one year to be free from defects in materials and workmanship. Repairs will be made at the factory, on products that are returned postpaid to the factory after permission or authorization for return is granted.

The warranty is **VOID** if the unit has been tampered with without express permission: if fuses of an incorrect type or rating have been used; if power has been incorrectly applied to the interlock Terminals 3 and 4, or for any other type of mis-use.

Aside from the above statement of warranty, **SALDET SALES & SERVICE, INC.**, its agents, employees, dealers and distributors assume **NO LIABILITY, AND SPECIFICALLY ASSUME NO LIABILITY FOR ANY CONSEQUENTIAL DAMAGE** due to malfunction, failure to function, improper application, or improper operation of these products.

No allowance can be made for removal or installation costs, machine downtime, transportation, etc.

**THE USER ASSUMES FULL APPLICATIONS RESPONSIBILITY.**