



Saldet Sales & Service, Inc.

44810 VIC WERTZ DRIVE, SUITE B
CLINTON TOWNSHIP, MICHIGAN 48036-1250
PHONE: (586) 469-4312 FAX: (586) 463-2518
1 (888) 621-6221

Form 1254

BRACKETRON[®]

Electronic Motor Brake Instructions

**SALDET SALES & SERVICE, INC.
CLINTON TOWNSHIP, MICHIGAN**

TABLE OF CONTENTS

SECTION	TITLE	PAGE
I.	Introduction	1
II.	Specifications	1
III.	Principles of Operation	2
IV.	Installation Instructions	4
V.	Braketrone Options and Diagram References	6
VI.	Braketrone Applications	8
VII.	Troubleshooting Chart and Testpoint Waveforms	9
VIII.	Connection Diagrams and Schematics	12
	Fig. 3 Braketrone Disable Option	
	Fig. 4 Emergency Stop Operation	
	Fig. 5 Mechanical Brake Release Option	
	Fig. 6 Remote Sense Option	
	Fig. 7 Standard Reversing Starter Connections	
	Fig. 8 Multispeed Starter Connections	

I. INTRODUCTION

The **BRACKETRON** is a solid-state dynamic motor brake for stopping AC squirrel cage motors. Units are available in a wide range of voltage and power ratings. **BRACKETRON** is designed to be maintenance free and is built for continuous use applications. This provides more reliable operation and eliminates expensive downtime caused by mechanical brake failure. **BRACKETRON** eliminates costly operator idle time during motor coastdown and helps equipment comply with national safety requirements for motor stopping. **BRACKETRON** is suitable for use in general and heavy duty applications to improve safety and maximize production efficiency.

Although not a holding brake, it's advantage over mechanical brakes is that **BRACKETRON** has no parts that wear or must be maintained and replaced regularly. In non-overhauling load applications, standard AC motors can be used rather than conventional brakemotors. A mechanical brake, however, should be used with **BRACKETRON** in positive locking situations.

This manual should provide sufficient information concerning **BRACKETRON'S** operation, specifications, installation, and trouble-shooting. If further information is required, consult the company.

II. SPECIFICATIONS

Input Voltage:	208, 230, 380, 415, 460, 500, 575, +/-10%, 3 Phase
Frequency:	50/60Hz, +/- 2Hz
Installation Location:	Indoor
Ambient Temperature:	0-45°C
Storage Temperature:	-20° - 70°C
Humidity:	0-95% Non-Condensing
Enclosure:	NEMA 12, IP54
Load Type:	Squirrel Cage Induction Motor
Output Stage:	1 SCR - Diode
Indication:	LED "Brake On"
Protection:	Fuse
Interlock:	Dry Contact
Frequency Tolerance:	+/- 2Hz

III. PRINCIPLES OF OPERATION

Braking AC motors by applying a direct current to the stator winding is not a new concept in industry. However, until the recent advancements in high power thyristors or silicon-controlled-rectifiers (hereafter referred to as SCR) technology, it has not been feasible to use this concept on the larger polyphase induction motors.

The **BRACKETRON** sends a pulsating direct current to the stator windings of an AC motor during the braking cycle. The resulting stationary magnetic field interacts with the induced rotor magnetic field and brings the rotor to a stop quickly and safely.

Referring to Figure 1, the complete automatic operation of **BRACKETRON** is carried out by the four functions (or blocks) as described in the following paragraphs:

1. TIMING CIRCUITS

This logic circuitry provides the following:

- a. A braking time interval (2-15 seconds as standard, longer or shorter ranges being optional). A potentiometer on the faceplate is used to set the desired braking time and once set for a given application, it should be locked down and not require re-adjustment.
- b. An interlock to the existing motor starter which will prevent energization of the motor with AC power during the braking cycle. This interlock is a normally-closed contact and will be wired in series with the existing starter coil or stop operator.
- c. A signal to the trigger circuit to fire the SCR device. This turn-on signal is applied immediately following closure of the braking contactor. This signal also stops prior to opening the braking contactor to ensure the braking contactor neither makes nor breaks any current.

2. TRIGGER CIRCUITS

The trigger circuit provides the firing pulses to turn on the SCR. This circuit controls the firing angle or conduction time of the SCR thereby controlling the braking torque of the motor. A potentiometer located on the faceplate is labeled "Braking Torque" and provides easy adjustment to suit breaking requirements. Once set for a given application, it should be locked down and not require re-adjustment.

3. SCR POWER CIRCUIT

BRACKETRON has an SCR-diode power circuit, the purpose of which is to conduct current to the motor stator-windings when commanded by the trigger circuit. The SCR provides the means for varying the braking current (torque) and the diode provides a return path for "inductive kickback." The braking contactor contains the isolation contacts necessary to electrically isolate the **BRACKETRON** unit when braking is not in progress. The power circuit incorporates two "fast-blow" semiconductor fuses for protection and isolation of the SCR-diode. RC snubbers and varistors are also included to protect the SCR and diode from transients.

4. SENSING CIRCUIT

The sensing circuit is used to sense AC power to the motor. This circuit controls the automatic operation of the **BRACKETRON** unit and, produces a "ready signal" when the motor is energized and initiates a braking cycle upon motor turn-off.

FIGURE 1

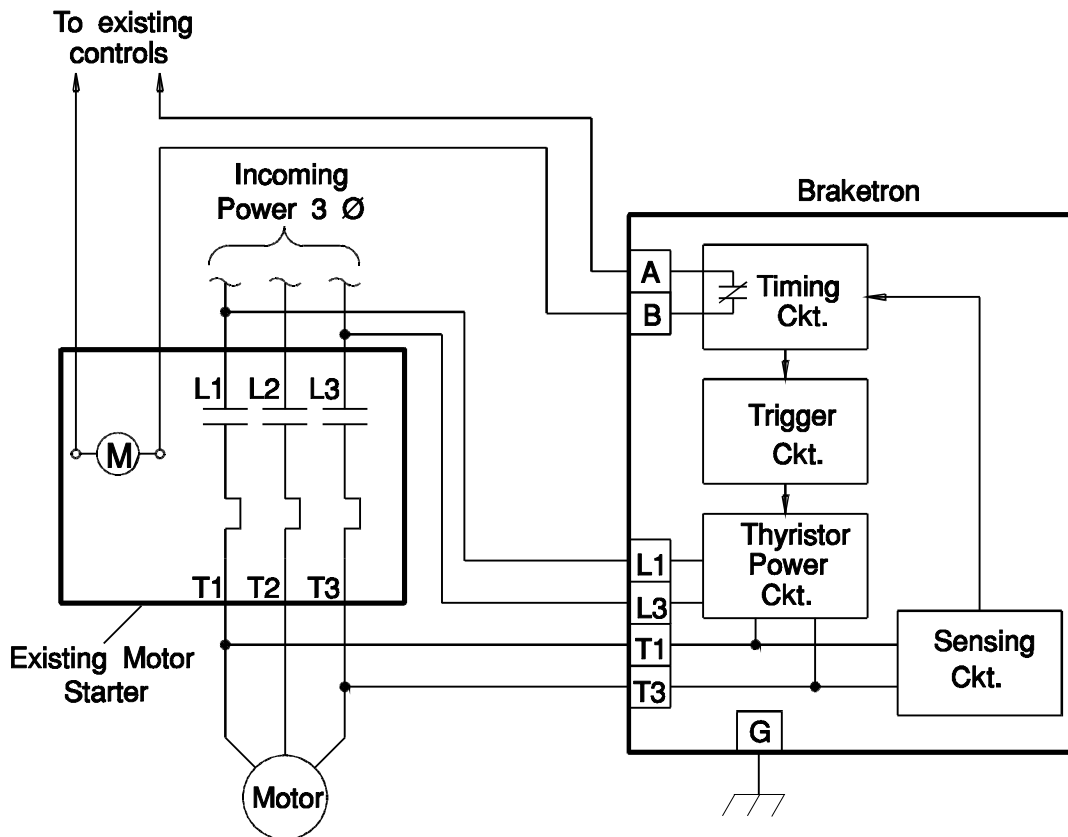

IV. Installation Instructions

WARNING!
TURN OFF MAIN POWER
before making any connections.

Consult section VIII for Wiring Diagrams for **BRAKETRON** options.

STEP 1 - See Figure 2 below

1. Connect terminals L1, L3 to line side of starter.
2. Connect terminals T1, T3 to motor side of starter.
3. Connect chassis of **BRAKETRON** to suitable ground.

STEP 2 - See Figure 2 below

1. Connect terminals A and B in SERIES with one side of the starter coil as shown or in series with motor STOP pushbutton.
2. On a reversing starter, connect terminals A and B in SERIES with the common wire feeding both starter coils or in SERIES with the STOP pushbutton.

NOTE: Terminals A and B access a normally closed interlock which will prevent starting the motor during the braking cycle. It is important that these terminals be connected properly. To check this connection, disconnect the wire which is connected to terminals "A", apply power and try to start the motor. The motor SHOULD NOT start. Disconnect the power. Reconnect the wire to terminal "A" following this test & continue to STEP 3.

FIGURE 2

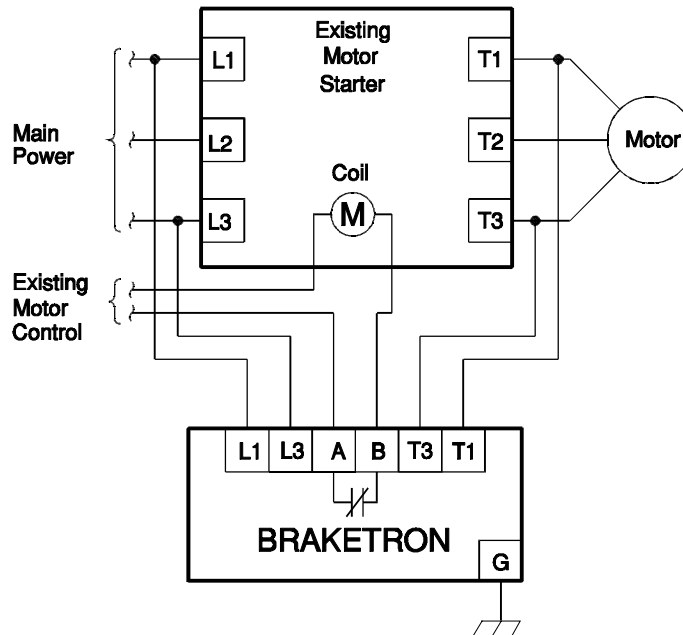

STEP 3 - Adjustment

1. Set the time control to midrange.
2. Set torque control to minimum (full counter clockwise).
3. Connect a clamp-on AC ammeter on wire "L1" connected to terminal "L1" on **BRACKETRON**. Check to see that current does not exceed 2 x motor full-load amps for motors 10HP (7.5kW) and less; or 1 x motor full-load amps for motors greater than 10HP (7.5kW).
4. TURN ON MAIN POWER and start motor.
5. Turn motor OFF and adjust torque control in increments 1/8 of a turn for desired braking rate. Braking action is indicated by a red indicator lamp on the faceplate and a slight hum in the motor. Do not attempt to brake the motor too quickly.
6. Adjust the time control so that the red indicator lamp goes out approximately 1 or 2 seconds after the motor has stopped.

NOTES:

1. See Figure 7 for standard reversing starter connections.
2. See Figure 8 for multispeed starter connections.
3. The wire used on terminals L1, L3, T1, T3 must be rated for full-load motor current.
4. Ensure the motor load is locked securely on motor shaft. High braking torque settings can loosen motor loads if they are not secured properly.
5. Do not operate the motor starter manually with the **BRACKETRON** connected.
6. **BRACKETRON** does not provide holding torque at zero speed.
7. Consult the company for modifications not listed or any special applications.

V. **BRAKETRON** OPTIONS AND DIAGRAM REFERENCES (* = Standard Codes)

1. **Chassis only (*CH)**

This unit is supplied with the chassis interior only, for installation by the customer in a control panel.

2. **Brake Disable Switch**

This function capability is standard with customer supplied control switch for interrupting a braking cycle in progress or taking the brake out of service without having to disconnect the wiring. A disable switch is available either mounted on the enclosure or in a remote control enclosure. Refer to Figure 3.

3. **Emergency-Stop Push-Button**

This function capability is standard with customer supplied control switch for energizing the brake on demand instead of after each motor running cycle. A separate emergency-stop pushbutton is available either mounted on the enclosure or in a remote control enclosure. Refer to Figure 4.

4. **Time Option - Other than 15 Second Standard (T_ _)**

There are occasions where the standard 15 second timer is not sufficient. Motors with high inertial loads may require longer timing circuits (i.e., 60 second, 90 second, etc.). However, if a longer timing circuit is needed, it must be specified at the time of order entry. Sometimes a larger than normal **BRAKETRON** may be required.

5. **Holding Brake: Releasing Spring-set Mechanical-brake after Electronic braking has finished (*MH)**

BRAKETRON is designed to replace electromechanical friction brakes in many applications. Its obvious advantage over mechanical brakes is that **BRAKETRON** has no parts that wear or must be maintained and replaced regularly. However, in some applications, a positive hold on the motor shaft must be maintained to prevent coasting, e.g.: incline conveyors. In this situation, **BRAKETRON** can be used in conjunction with a mechanical brake. **BRAKETRON** performs the braking and the mechanical brake the holding. This provides the reliability of electronic braking and gives the holding brake virtually an indefinite life, for there will be practically no friction or wear on it. This option must be specified at the time of order entry. Refer to Figure 5.

6. **High Torque (*HT)**

This option provides approximately 2 to 4 times the stopping torque capability of a standard unit. A standard unit, at maximum torque, is designed to stop a motor in approximately 150% of time the motor takes to reach full speed at start-up. This is sufficient in most cases, however some applications require further braking torque such as high inertia centrifugal loads or process machines that require very rapid stops. In this type of situation, a high torque unit may be necessary. Consult the company for information.

7. Enclosures Other Than Standard

Non standard and special enclosures are available for particular applications.

8. Remote Sense Terminal to Engage Braking Upon command (e.g., multi-speed motors, reduced voltage starters) (*RS)

The remote sense option provides a means of operating the brake by the closure and subsequent opening of an auxiliary contact. This option is required for braking multi-speed motors with one **BRAKETRON** unit and for reduced voltage starters to prevent false cycling of **BRAKETRON**. Refer to Figure 6.

9. 415V, 50Hz Unit Modification for use on 380V, 50Hz

380V, 50Hz **BRAKETRON's** are available by selecting the appropriate power at 415V and derating by 8.5% (for example: 7.5kW, 415V, 50Hz derates to 6.9kW at 380V, 50Hz).

VI. BRAKETRON APPLICATIONS

1. Types of motors on which **BRAKETRON** can be used

BRAKETRON is designed for use with single or 3-phase AC induction motors. **BRAKETRON** is NOT designed for use with AC synchronous or DC motors. **BRAKETRON** should be sized according to power, voltage, phase and load-inertia.

2. Multiple Motor Operation

BRAKETRON can be used in multi-motor applications when one starter is operating those motors which are to be stopped. The power of all the motors must be added together in order to size the brake correctly.

Example: Three 10HP (7.5kW) motors are being started by one starter. A **BRAKETRON** rated to at least 30HP (22.5kW) must be used. Where each motor is started by an individual starter, a separate **BRAKETRON** for each motor is recommended.

3. Power failure

BRAKETRON requires AC power to operate. Thus, in the event of a power failure, no braking will occur and the load will coast to a stop. If a quick stop or holding is required in a power failure situation, the use of an electromechanical fail-safe brake is recommended. A **BRAKETRON** equipped for this application is available as an option. See Figure 5 for the connection diagram.

4. High cyclic rates of braking

Dynamic braking causes some motor heating. However, in high cyclic or continuous inching operations, a rule-of-thumb is to limit braking to approximately 8 times per-minute. However, we recommend contacting the motor manufacturer or our company to determine the heat loading of the motor.

VII. TROUBLESHOOTING CHART

This chart is designed as an aid in locating a faulty component within the **BRACKETRON** unit. It will point the technician to the group of components associated with the faulty function. At this point the technician should be able to locate and replace the defective component.

When it is important that a unit be returned to service immediately, replacing the faulty circuit card is recommended. The faulty card can then be returned to the company for repair.

Always check initially for correct installation, good connections and wiring integrity. This can often solve many problems.

Test Equipment Required

1. Standard volt-ohm (multi) meter.
2. Standard oscilloscope.



Symptom	Possible Cause	Remedy
Brake does not function. Indicator light <u>does not</u> illuminate.	Installation wiring incorrect.	1. Recheck all steps of installation instructions.
	Blown fuse (improper installation).	1. Replace fuse and recheck all steps of installation instructions.
	Blown fuse (excessive braking current).	1. Replace fuse and reduce current (torque). Recheck Step 3 of installation instructions.
	Blown fuse (shorted SCR and/or diode).	1. Replace shorted SCR or diode and replace fuse. 2. Investigate for cause of shorted device (arcing, excessively high line volts, blown varistor).
	Defective transformer.	1. Check for approximately 20VAC on PC board pins 1 and 2.

Symptom	Possible Cause	Remedy
Brake does not function. Indicator light <u>does not</u> illuminate.	Defective PC board.	<ol style="list-style-type: none"> 1. Check for approx. +15VDC on PC board pins 14 (+) and 7(-). 2. Perform waveform check on TP1, 2, 3, 4, 5 and 6. 3. Replace defective component or entire PC board.
Brake cycles but no braking torque is produced. Indicator light <u>does</u> illuminate but no braking torque at any setting.	Faulty interconnections. Blown fuse(s). Defective PC board.	<ol style="list-style-type: none"> 1. Check quick-connect connectors for good connection. 1. Check and replace, if necessary. 1. Perform waveform check on TP1, 2, 3, 4, 5 and 6. 2. Replace defective component or entire PC board.
Brake cycles but has no time control. Adjusting time pot has no effect.	Faulty interconnections. Defective PC board.	<ol style="list-style-type: none"> 1. Check quick connectors for good connections. 1. Replace PC board. (Do not attempt to troubleshoot any further).
Brake cycles and the braking hum is audible but motor will not stop properly.	One blown fuse. Defective SCR-diode power circuit.	<ol style="list-style-type: none"> 1. Check and replace, if necessary. 1. Replace if defective.

TEST POINT WAVEFORMS

NOTES:

1. These checks require the unit to be energized. Ensure all high voltage safety precautions are observed and DO NOT work alone.
2. PC board pin "7" is common for all checks.
3. Refer to schematic diagram for circuit functions being tested.

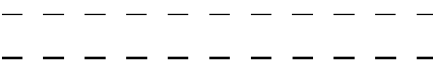
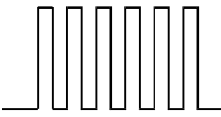
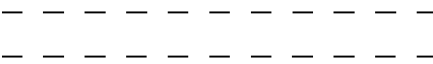
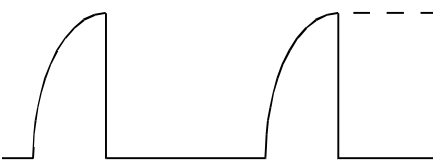
Test Point	Waveform/Voltage	Test Conditions
1 (P3 Adj.)	3.5 VDC -----	208 - 240VAC input (L1, L3)
	5.5 VDC -----	380VAC input (L1, L3)
	6.5 VDC -----	415VAC input (L1, L3)
	7.5 VDC -----	440 - 480VAC input (L1, L3)
	10 VDC -----	550 - 600VAC input (L1, L3)
2		4 - 14V 60 Hz Motor running 0V
3		15V 60 Hz Motor running 0V
4		Braking in progress Braking off
5		15V 32kHz Braking in progress 0V
6		Braking in progress Braking off
7		15V 60 Hz Braking in progress 0V

VIII. CONNECTION DIAGRAMS AND SCHEMATICS

Figure 3

Braketron Disable Option

PC BOARD (PCA101-01)

NOTES:

1. PC pins 6 and 7 should have a double male connector installed.
2. The Braketron unit will not function when switch is in "Disable" (OFF) position.

The Braketron unit will cycle normally following motor turn-off when switch is in "Enable" (ON) position.

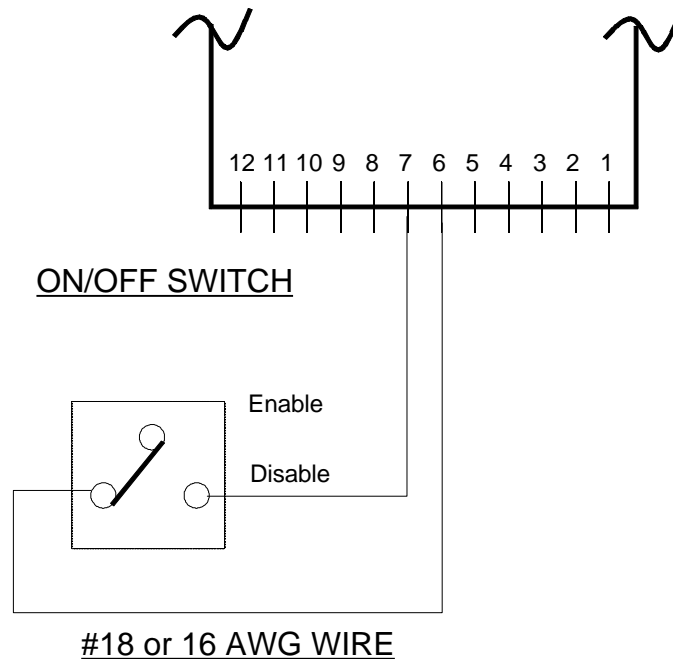

Figure 4

Emergency Stop Operation

NOTES:

1. Normal motor turn off will not engage BRAKETRON.
2. Depressing the Emergency Stop Operator will disengage starter(s) and engage BRAKETRON.

Emergency Stop Operator

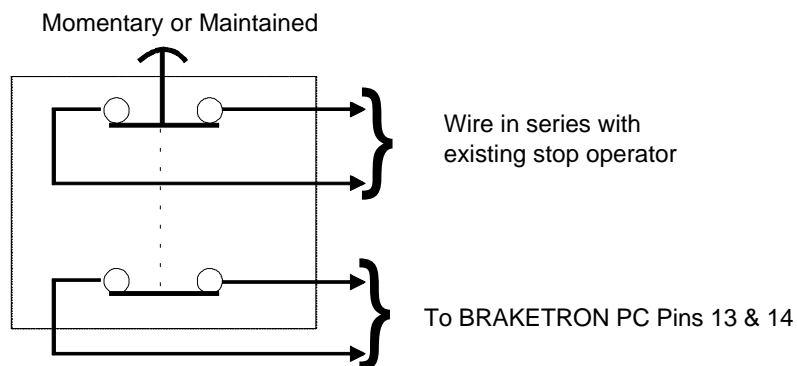

Figure 5

Mechanical Brake Release Option

1. See Figure 2.
On the brake release contactor, connect 3-phase power to L1, L2, L3 and brake coil leads to T1, T2, T3. (Omit connections to L2 and T2 if single-phase).
2. Connect a normally-open auxiliary contact from the existing motor starter to **BRACKETRON** pc board pins 1 and 10. These pins are provided with a spare connector for ease of installation. (If the existing installation utilizes a reversing starter, a normally-open auxiliary contact from each contactor must be paralleled then connected to pc board pins 1 and 10).
3. Follow normal **BRACKETRON** installation instructions provided with the unit except under Step 3, numbers 5 and 6, adjust this unit so the mechanical brake releases just before the motor shaft is completely stopped. This ensures no slip during the electronic-mechanical brake changeover.

Note:

If the existing installation utilizes reversing and multispeed contactors, then a "normally-open" auxiliary contact from each contactor must be paralleled and connected to pc board pins 1 and 10.

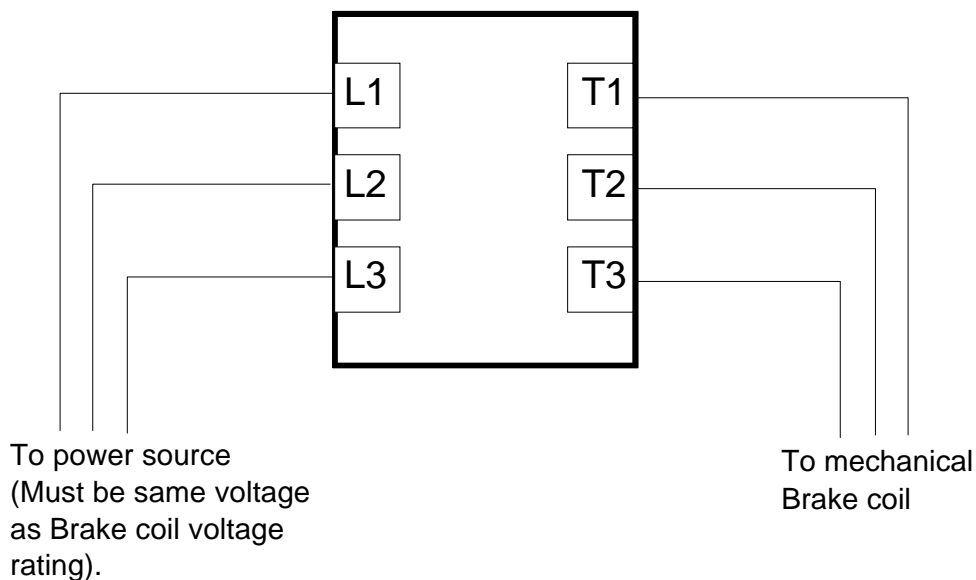
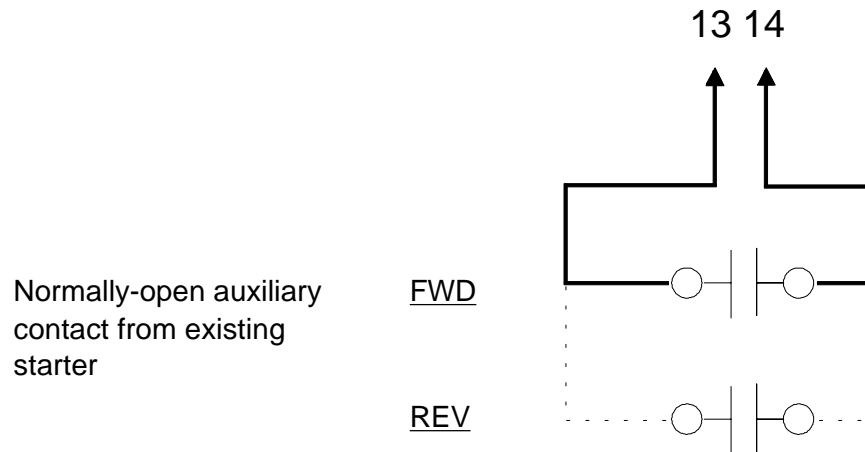

Figure 6

Remote Sense Option

BRAKETRON Option Terminals



NOTES:

Braketron terminals A and B should be wired in series with stop button or starter coil. See Step 2 of Installation Instructions (Chapter IV).

If a reduced-voltage starter is being used, the normally open contact as shown should be from the "RUN" contactor. Disconnect and clip out wires on PC board pins 15 and 16 which connect to T1 and T3 power terminals. Install a jumper between pins 15 and 16.

Figure 7

Standard Reversing Starter Connections

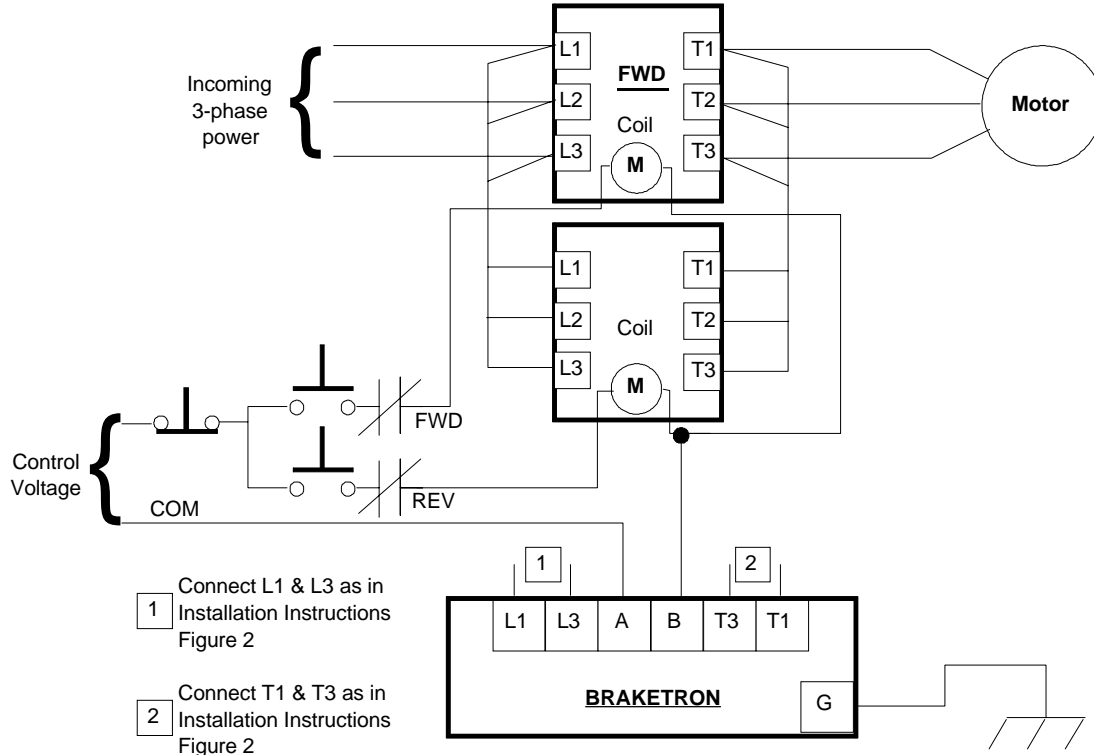

Figure 8

Multispeed Starter Connections

