



Saldet Sales & Service, Inc.

44810 VIC WERTZ DRIVE, SUITE B
CLINTON TOWNSHIP, MICHIGAN 48036-1250
PHONE: (586) 469-4312 FAX: (586) 463-2518
1 (888) 621-6221

Form 1289

FAN-STOP

Instructions

**SALDET SALES & SERVICE, INC.
CLINTON TOWNSHIP, MICHIGAN**

FAN-STOP

INSTRUCTION MANUAL

IMPORTANT

Read these instructions fully **BEFORE INSTALLING**. Equipment damage and personal injury may result from improper installation and/or use.

1. **Instructions**

1.2 Fan Stop

The Fan Stop anti-windmilling motor brake, senses when a start is attempted and performs an electronic braking cycle first. The fan is decelerated before it can be started to prevent starting from a reverse direction.

2. **Installation and Wiring**

2.1 Mounting

Since heat is produced in the Fan Stop control unit, it is important that the device be mounted in a manner to best be able to dissipate heat.

If the Fan Stop is supplied as a “module”, the enclosure should be large enough to allow free circulation of air past the heat sinks.

2.2 Control Wiring

Wires connected to Terminals 3, 4, 7, S, and W will be required to carry control currents only. These may be of the same gauge as those connected to the existing motor starter coil.

2.2.1 Interlock - Terminals 3 and 4

This part of the installation **MUST** be done before the main power wiring described in section 2.3 The purpose of the interlock is to electrically isolate i.e., lock out the starter contactor during the Fan Stop mode.

MAXIMUM CONTROL VOLTAGE IS 240 VAC
This is the most important part of the installation. Please read the instructions CAREFULLY!

If the interlock is not connected properly, it may be possible to engage the run contactor during the Fan Stop mode, which will damage the unit.

Terminals 3 and 4 must be placed in SERIES with the common return wire of ALL starter contactors in the system. **NEVER CONNECT TERMINALS 3 AND 4 ACROSS (IN PARALLEL WITH) THE CONTACTOR COIL, OR ACROSS THE POWER LINE!**

Some common connection points for terminals 3 and 4 include placement in series with the motor overload protection contracts or in series with the control system stop button. Refer to Page 5, Figures 2.4 – 2.6, for some typical control systems with the interlock Terminals 3 & 4 wired properly.

After making the interlock connections, the following test must be performed to insure that the wiring is indeed correct.

- [] With main power off, lift wire from terminal 4
- [] Apply control (main) power and attempt to start the motor. **IF THE MOTOR STARTS, YOUR WIRING IS NOT CORRECT.** Turn power off, re-read the material in this section, revise your wiring and try again. If the motor does not start, reconnect terminal 4 and continue with the installation procedure.

DO NOT PROCEED UNTIL YOU HAVE SELECTED THE CORRECT WIRES TO PASS THIS TEST. CALL THE FACTORY FOR ASSISTANCE IF NECESSARY.

2.2.2 Wiring of Option Terminals

- [] Autotime-out sensor: connect a wire from T2 on the starter contactor to terminal 7.
- [] Make available from each starter in the system, a DRY, normally open auxiliary contact. Wire all contacts in parallel and connect to terminals S & W. Terminals S & W are located on the right side of the logic circuit board.

2.3 Power Wiring

Fuses within the Fan Stop are provided for the protection of the internal semiconductors only. The user must provide additional fusing (in accordance with NEC standards) for the protection of the wiring and motor.

Connections are to be made in accordance with installation diagram and should conform to national and local electrical codes.

In general, the wires connected to Terminals 1, 2, 5, and 6 must be the same gauge as the motor wires.

Before installing the Fan Stop, be certain that the power is turned off and locked out. Power should only be applied after all work has been checked, all connections tightened, and all safety features reinstalled.

Connect motor Terminals 5 and 6 to the motor. Terminal 5 connects to T3 and terminal 6 to T1.

Connect power Terminals 1 and 2 to the motor power source, down stream from a suitable positive disconnect as required by the National Electric Code. Terminal 1 should be connected to L1 and terminal 2 to L3. Refer to Page 5, Figures 2.1 – 2.3, for some typical power wiring arrangements.

3. Adjustments

3.1 Torque

An attempt to engage the starter contactor will result in a transfer into the Fan Stop Mode. The Fan Stop will decelerate the fan to zero speed, and then allow it to start. The rate of deceleration may be adjusted via the **FAN TORQUE** control, located on the top circuit board.

- [] Adjust the Fan Torque control to mid-position.
- [] Apply main power and wait 30 seconds.
- [] Actuate the motor start control.
- [] The fan will be decelerated to zero speed and then the motor will be allowed to start. NOTE: if the fan has not reached zero speed before the starter contactor was allowed to engage, increase the Fan Torque control.

The time between when the start command is issued and the motor actually starts will vary depending upon the windmill and deceleration rates. An automatic timeout circuit disengages the brake at zero speed to keep the delay as short as possible at all times. (The maximum “wait” time in the Fan Stop Mode is 60 seconds)

4. Limitations and Special Characteristics

4.1 System Rest Mode

If the start command is canceled before the fan reaches zero speed, the unit will revert to the Rest Mode; both the red and green LED's on the middle circuit board will be out. (In this mode, no current is output to the motor.) The next time a start command is issued, the motor will start directly without the Fan Stop deceleration. Switching the main power off for several seconds, and then on will reset the unit.

4.2 Power or Fuse Failure

Loss of power means loss of braking, regardless of whether power is disconnected by a switch, line or internal fuse. This also applies to the Fan Stops internal fuses.

4.3 Power Factor Capacitors

Power factor capacitors may NOT be used across the load. Move any such capacitors to the LINE side of the starting contactor.

4.4 Holding Against a Load.

The Fan Stop cannot be used as a holding brake.

5. Warranty

Each Saldet product is warranted by the factory for one year to be free from defects in materials and workmanship. Repairs or replacement will be made at the factory, after return authorization, on products returned prepaid.

The warranty is VOID if the unit has been tampered with, if fuses of an incorrect type or size have been used, if power has been incorrectly applied to the interlock Terminals 3 and 4, for any other type of misuse.

Aside from the above statement of warranty, Saldet Sales and Service, Inc. , its agents employees and dealers assume NO LIABILITY, and specifically assume NO LIABILITY FOR ANY CONSEQUENTIAL DAMAGE due to malfunction, failure to function, or improper application of it's products. **THE USER ASSUMES FULL APPLICATIONS RESPONSIBILITY.**

No allowance can be made for removal or installation costs, machine downtime, transportation costs, etc.

6. Figures

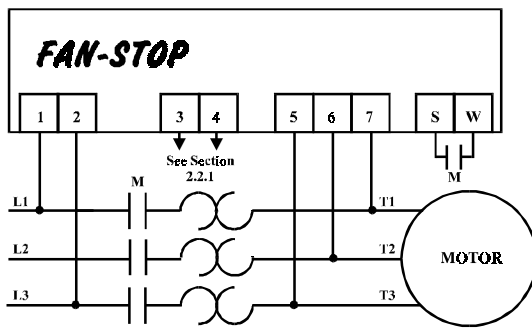

Figure 2.1

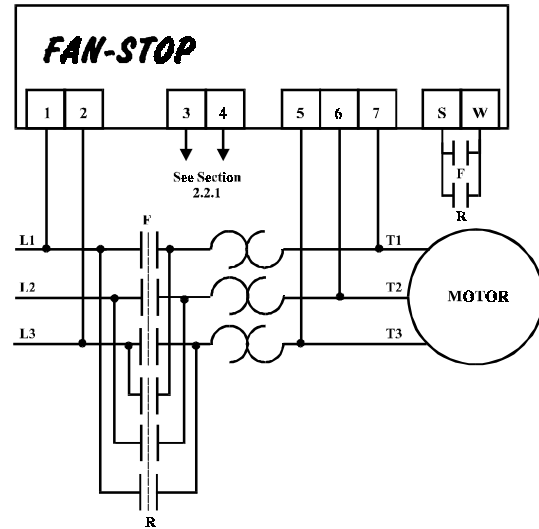

Figure 2.2

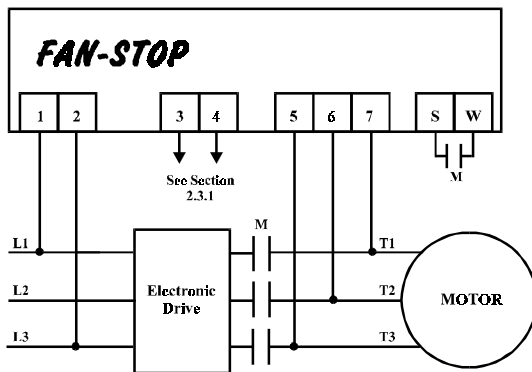

Figure 2.3

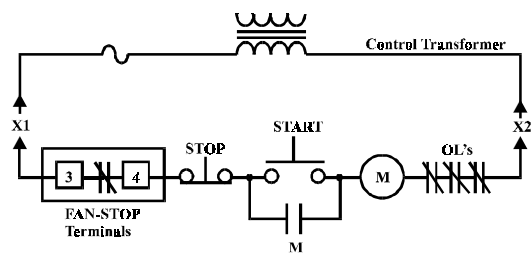

Figure 2.4

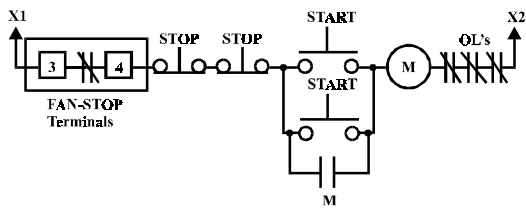

Figure 2.5

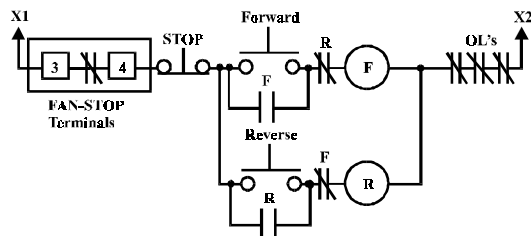

Figure 2.6